

Example of order: MAV 2061 - 6 x 22 (d x D)

Features

- shaft - hub locking device with medium to high torque capacity
- single taper design, self-centering, self-locking
- general purpose unit, particularly recommended for servo- and stepping-motors
- no axial movement of hub during installation
- good bending moment capacity
- shaft tolerance h7-h11; hub bore tolerance H7-H11
- shaft and hub bore surface finish $Ra < 3,2 \mu m$

Application examples

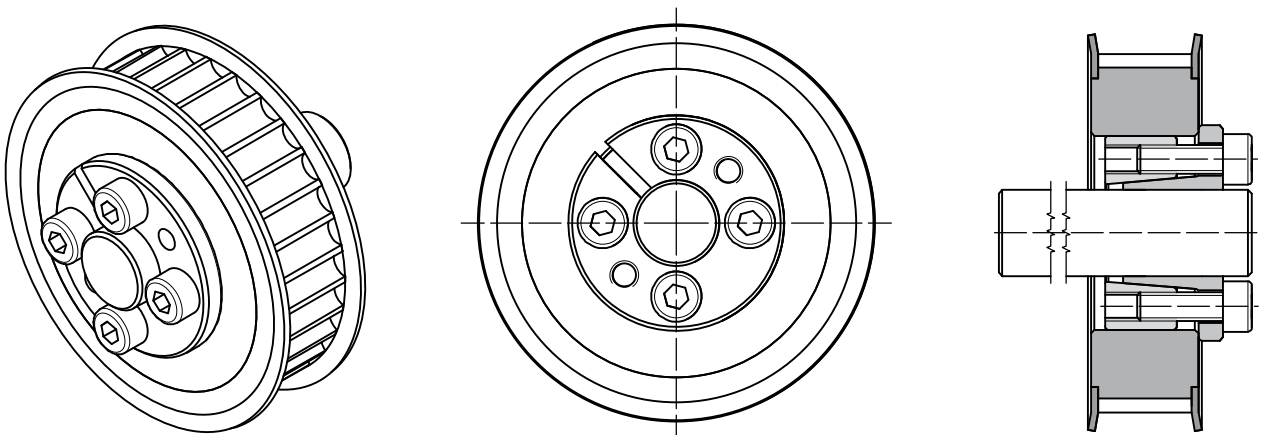
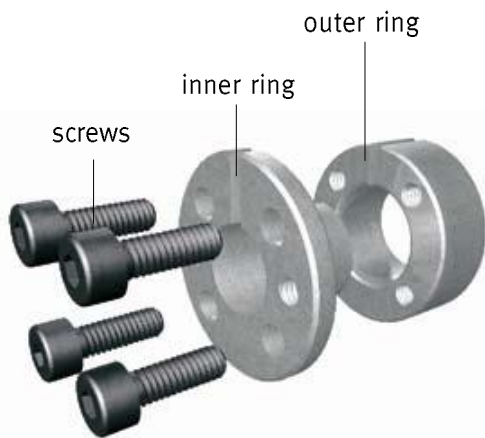

Fig.1: fastening of a drive pulley with MAV 2061

Composition

- slotted inner ring, with intergrated push-off threads
- slotted outer ring
- set of socket head cap screws, grade 12.9



Components of MAV 2061

DIMENSIONS						SCREWS					
d	x	D	D1	L	L1	size	Ma	Mt	Fax	Ps	Ph
mm		mm	mm	mm	mm		Nm	Nm	kN	N/mm ²	N/mm ²
6	x	22	25	20,5	13,1	M 4	5	22	7,3	323	88
7	x	22	25	20,5	13,1	M 4	5	26	7,3	277	88
8	x	22	25	20,5	13,1	M 4	5	29	7,3	242	88
9	x	25	28	20,5	13,1	M 4	5	33	7,3	215	77
10	x	25	28	20,5	13,1	M 4	5	37	7,3	194	77
11	x	27	30	20,5	13,1	M 4	5	54	9,7	235	96
12	x	27	30	20,5	13,1	M 4	5	58	9,7	215	96
14	x	30	33	24,5	15,1	M 4	5	102	14,6	231	108
15	x	30	33	24,5	15,1	M 4	5	110	14,6	215	108
16	x	30	33	24,5	15,1	M 4	5	117	14,6	202	108
17	x	34	37	24,5	15,1	M 4	5	124	14,6	190	95
18	x	34	37	24,5	15,1	M 4	5	131	14,6	179	95
19	x	34	37	24,5	15,1	M 4	5	139	14,6	170	95
20	x	40	45	30	19,2	M 5	10	235	23,5	207	104
22	x	40	45	30	19,2	M 5	10	258	23,5	189	104
24	x	43	48	30	19,2	M 5	10	375	31,3	230	129
25	x	43	48	30	19,2	M 5	10	391	31,3	221	129
28	x	50	55	33	21,2	M 5	10	547	39,1	218	122
30	x	50	55	33	21,2	M 5	10	586	39,1	203	122
32	x	55	60	33	21,2	M 5	10	625	39,1	191	111
35	x	55	60	33	21,2	M 5	10	684	39,1	174	111

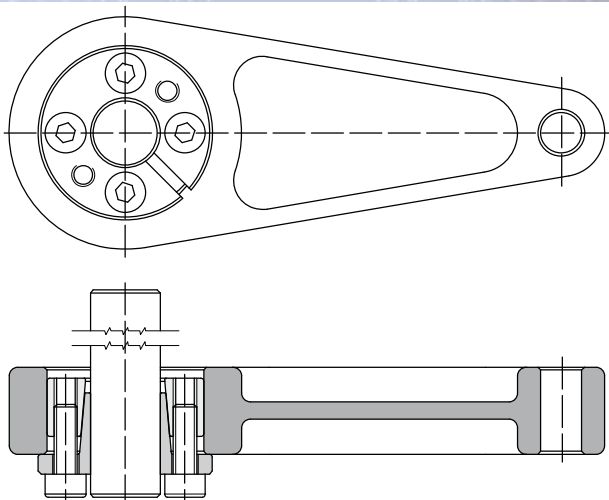

Fig.2: mounting a lever arm with MAV 2061

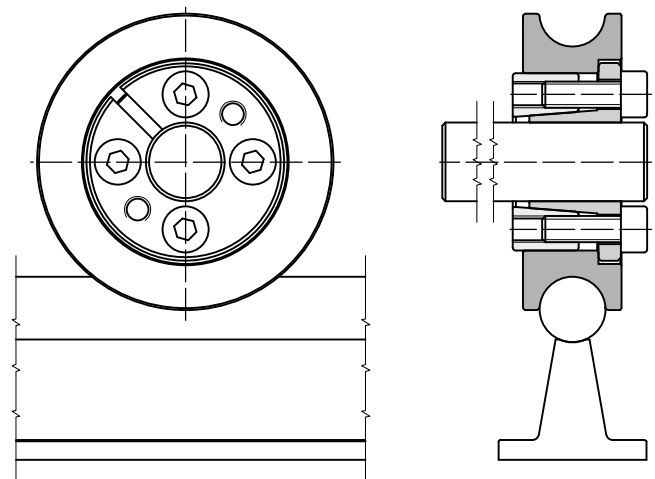

Fig.3: using MAV 2061 to connect a linear wheel